



## THE AIR TO WATER HEAT PUMPS

# HIGH TIME FOR ENERGY EFFICIENT AND CLEVER SOLUTIONS!

The climate is changing. The effects are visible throughout the world and even the speed of this change seems to be increasing.

Your customer sees and hears this every day.

To limit the consequences of global warming as much as possible, CO<sub>2</sub> emissions must decrease.

Your customer knows this.

The supply of fossil fuels is finite and this leads to continuously higher fuel prices.

Your customer feels this (in his wallet).

Furthermore, your customer wants a heating solution that uses less energy.

Just like you, your customer realises it is time to switch to a heating system that is energy efficient and which produces low CO<sub>2</sub> emissions.

The Altherma heat pump is a durable energy system that transforms unutilized, and inexhaustible, energy from the outside air into usable heat. Altherma is best combined with low temperature heating systems and aims to achieve optimal comfort. Moreover, Altherma is easy to install.

## ALTHERMA HEAT PUMP



COOLING

HEATING

## 3 IN 1 SYSTEM

## FOR NEW CONSTRUCTIONS

## & RENOVATION

> MORE COMFORT

> LOW ENERGY CONSUMPTION

> FEWER CO<sub>2</sub> EMISSIONS



DOMESTIC HOT WATER PRODUCTION

## ■ ALTHERMA Pag 4

### THE REVOLUTION IN HEATING COMFORT!

Your customers are also conscious of the ever increasing energy prices and the effects of global warming. With Altherma, you give them the ability to personally contribute toward a sustainable lifestyle which respects the environment.

### 1. ALTHERMA, Page 6 THE BASICS

### 2. ALTHERMA, Page 8 TECHNICALLY

### 3. ALTHERMA, Page 14 ECONOMICALLY

### 4. ALTHERMA, Page 15 THE SOFTWARE

### 5. ALTHERMA, Page 16 TECHNICAL SPECIFICATIONS

### 6. SERVICE Page 22 WE ARE HERE FOR YOU!

Do you need assistance with an installation or a start-up? You are having difficulty resolving a technical problem? One telephone call is all it takes to receive the help you need.

# ALTHERMA THE 3 IN 1 GUARANTEE FOR ABSOLUTE COMFORT

Altherma is a unique system that **heats**, produces **domestic hot water** and can even **cool** spaces. Thus Altherma offers your customer maximum comfort the whole year through.

Heat pumps are also an interesting alternative for classic gas or fuel oil heating as they offer your customers unique benefits:

- > they use renewable energy sources (such as outside air)
- > they deliver considerable savings in energy
- > they deliver a significant contribution in the fight against CO<sub>2</sub> emissions
- > they can provide heating, cooling and domestic hot water

## ENERGY EFFICIENT OPERATION

The air/water heat pump from Altherma uses a sustainable energy source. In fact, it extracts heat from the outside air. The system consists of a closed circuit containing a refrigerant. A thermodynamic cycle is created through evaporation, condensation, compression and expansion. A heat pump “pumps” heat from a low to a high temperature level. The heat raised is transferred to the water distribution system (under floor heating, low temperature radiators and/or fan coil units) in the home via a heat exchanger.

Depending on the model and the conditions, an Altherma air/water heat pump delivers between 3 and 5 kWh of usable heat for every kWh of electricity it uses. So this means that approximately 2/3 to 4/5 of the required heat is free!

Heat pump combination	Heating range	Cooling range	Domestic hot water
ERHQ006-008AD + EKHBH008AA	5,75 tot 8.43 kW + back up 3 kW to 9 kW	-	Option
ERHQ011-016AA + EKHBH016AB	11,2 tot 16,00 kW + back up 3 kW to 9 kW	-	Option
ERHQ006-008AD + EKHBX008AA	5.75 tot 8.43 kW + back up 3 kW to 9 kW	7,20 tot 8,37 kW	Option
ERHQ011-016AA + EKHBX016AB	11,2 tot 16,00 kW + back up 3 kW to 9 kW	13,9 tot 17,8 kW	Option

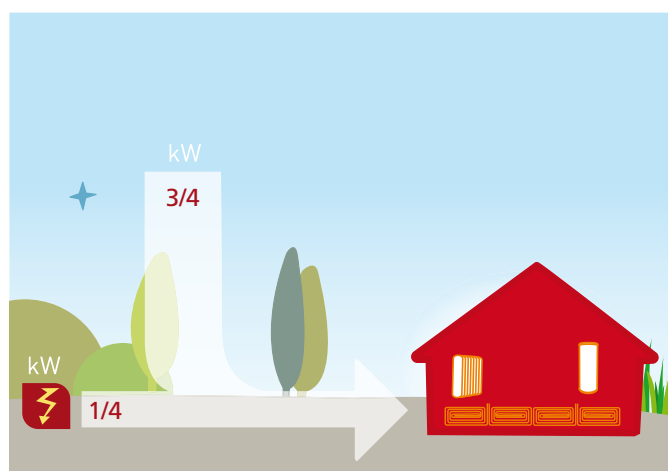

## TWO BASIC CONCEPTS OF HEAT PUMP TECHNOLOGY

### COP (Coefficient of Performance) or gain factor

This number indicates the amount of usable heat the heat pump delivers for every kWh electricity the heat pump uses. This number is dependent on the interior and exterior temperature and is therefore only a snapshot indicator.

### SPF (Seasonal Performance Factor) or performance factor of the heat pump system

The SPF takes into consideration both the energy consumption of the heat pump system as well as the consumption by peripheral equipment, such as pumps, over the entire heating season.

## A GOOD ALTHERMA DESIGN IN 3 STEPS

STEP 1

Calculation of heat losses  
(Transmission and ventilation losses)

STEP 2

Selection of Altherma based on heat loss calculation  
and preferably for a low water temperature regime (40-35°C)  
Tip: Use the available Daikin selection and software tools (see page 23)

STEP 3

Selection of emission systems, after choosing Altherma unit, with a  $T = 5$   
Tip: Remember to consider the pump characteristic of the provided circulator!

## HEATING DEMAND VERSUS HEATING SUPPLY

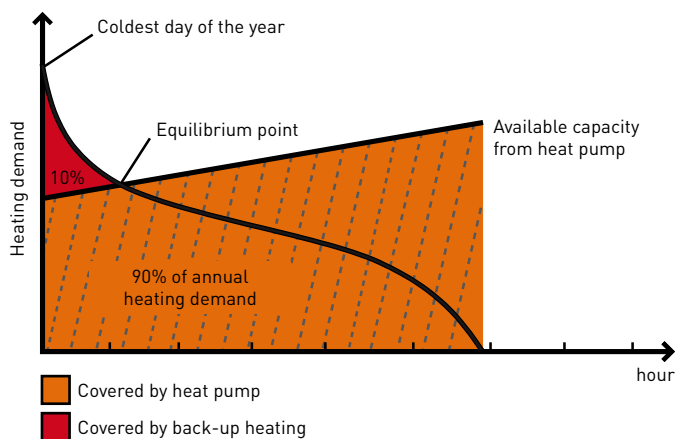

The need for heating will be the greatest on the coldest day of the year. The maximum heating demand is, in our regions, only required for a few hours per year.

Selecting a heat pump that covers the entire heating demand is not the most economical solution. In that case, the heat pump would be sized too large and the investment costs would be high.

A **mono-energetic solution** results in a **better balance between investment cost and consumption cost**. In such a case, the heat pump provides the largest portion of the heating demands but, in extremely cold weather, it is supported by an electric back-up heater. The back-up heater is only utilised at temperatures below the equilibrium point.

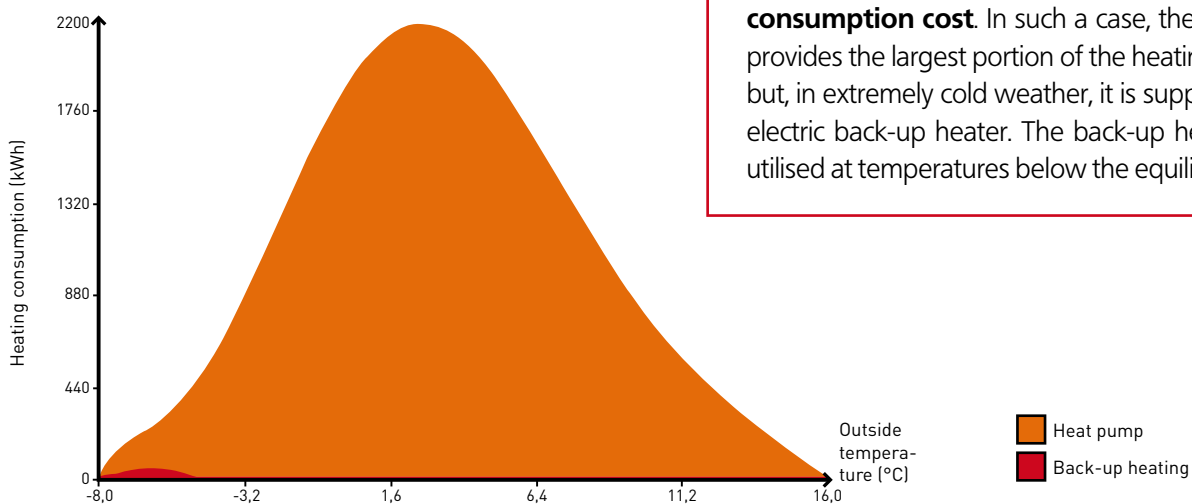

# 1. ALTHERMA. THE BASICS

## HOW DOES THE ALTHERMA HEAT PUMP WORK?

The principle is quite simple. The system consists of **4 components** which together provide the ideal environmental and water temperature.

### 1 - THE OUTDOOR UNIT

The outdoor unit is the actual heat pump. It extracts heat from the outside air and raises it to a sufficient temperature. The heat gained is pumped through a refrigerant circuit to the hydraulic module or indoor unit.

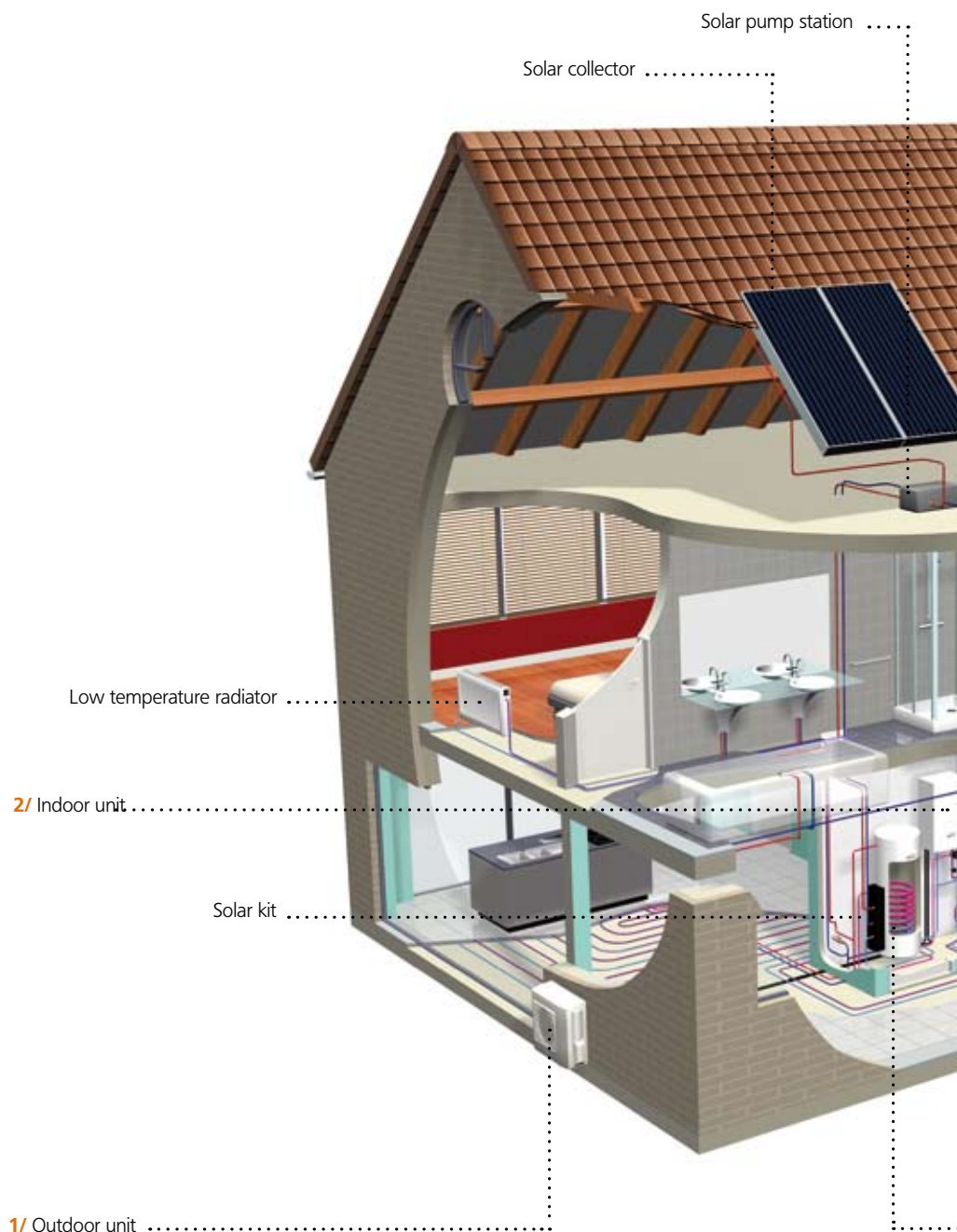

## 2 - THE INDOOR UNIT converts the energy

- > The indoor unit transfers the heat from the heat pump to the water in the distribution system (domestic hot water tank, under floor heating elements, low temperature radiators and/or fan coil units).
- > In the case of cooling, the heat is withdrawn from the water circuit (fan coil units and/or under floor heating elements) and released to the outside air via the heat pump.

### THE USER INTERFACE

The weather dependent interface, possibly supplemented with a room thermostat and/or independent zone-control, guarantees pleasant, comfortable heating at any moment. The user interface is integrated in the indoor unit.

## 3 - THE DOMESTIC HOT WATER TANK guarantees the ideal water temperature

The indoor unit pumps hot water through the integrated heat exchanger, which heats the water in the domestic hot water tank. The tank is equipped with an electric booster heater for additional heating.

Additionally, the Altherma system combines perfectly with solar panels to produce hot water. With a solar kit, the sun can provide 30 to 70% of the energy for your customer's hot water needs.

## 4 - THE ROOM THERMOSTAT

With the wired or wireless room thermostat, the ideal temperature can be easily, quickly and conveniently regulated. As an option to the wireless room thermostat, an external sensor (EKRTETS) can also be placed between the under floor heating and the floor. It allows for more precise measurement and can regulate the comfort level of your customer even more optimally and energy efficiently.

\*EKRTW for wired wall-mounting and EKTRR for the wireless type.

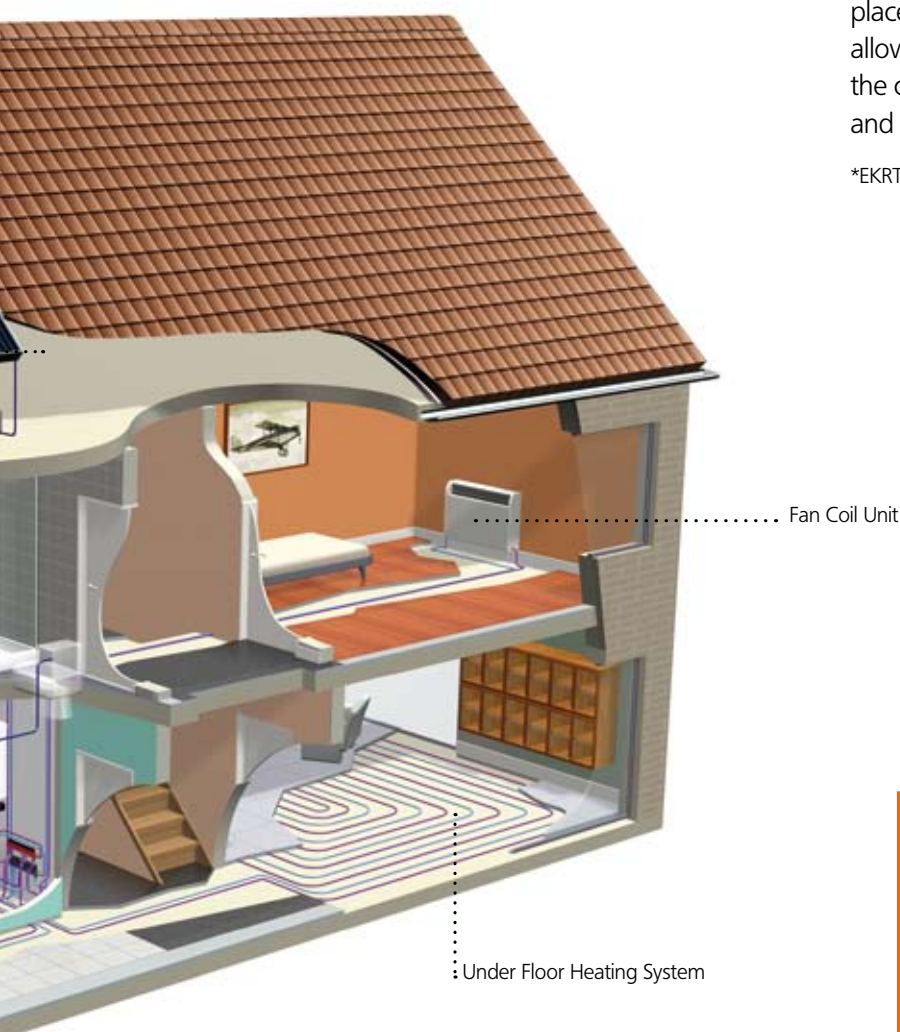

3/ Domestic hot water tank

# 2. ALTHERMA. TECHNICALLY

## 1 - THE AIR TO WATER HEAT PUMP

> reversible air/water heat pump ERHQ

### 1.1 - THE OUTDOOR UNIT

- > compact, weather-resistant and easy to install
- > contains a inverter controlled compressor for energy efficiency and precise temperature regulation
- > heat pump operation range: heating and domestic hot water to -20C° outside temperature



### HEAT EXCHANGER ANTI-CORROSION TREATMENT

As a standard, the heat exchanger in the outdoor group is provided with an anti-corrosion treatment. This treatment guarantees and noticeable increase in resistance against acid rain and salt corrosion.

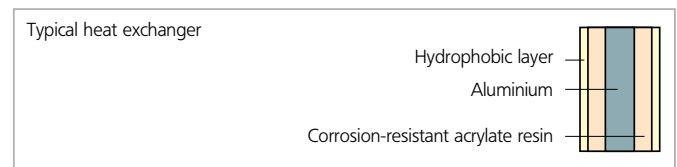

### SUPER PERFORMANCE THANKS TO THE INVERTER PRINCIPLE

The coefficient of performance (COP) of the Altherma heat pump is also largely attributable to the Daikin inverter principle. An integrated frequency-converter adjusts the rotational speed of the compressor to suit the heating demand. Therefore the system seldom operates at full capacity and your customer only pays for the energy which he actually needs.

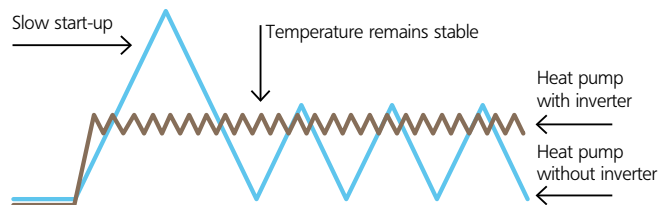

### HIGH EFFICIENCY COMPRESSORS:



Altherma models 6, 7 and 8 are equipped with a **swing-compressor**. Swing-compressors have been setting trends in the area of energy efficient performance for the past 10 years (leaks and friction are basically non-existent).



The **scroll-compressors** provided in the Altherma models 11, 14 and 16 are designed as compact, robust, low-noise device to guarantee optimal operational reliability (no valves and built-in swing-link coupling) and efficiency (through a low initial flow and a constant compression ratio).



## 1.2 - THE INDOOR UNIT

- > available in two versions: EKHBH for heating only, EKHBX for heating and cooling
- > **built-in electric back-up heater** as additional heating during extremely cold outdoor temperatures or as back-up in case of problems with the outdoor unit
- > **2 shut-off valves** to assemble the water outlet and inlet
- > compact and easy to install: all components are pre-assembled, all parts are easy to reach for maintenance. Wall-mounting is comparable to a traditional gas heater.
- > unique advantage: no natural gas or fuel oil connection or exhaust fume channel required

1. Heat exchanger
2. Expansion tank (10 litres)
3. Circulator
4. Tank with back-up heating
5. Air purge valve
6. Refrigerant fluid connection
7. Refrigerant gas connection
8. Water inlet connection
9. Water outlet connection
10. Pressure gauge (water circuit)
11. Water filter
12. Pressure relief valve
13. User interface
14. Switch box
15. Flow switch

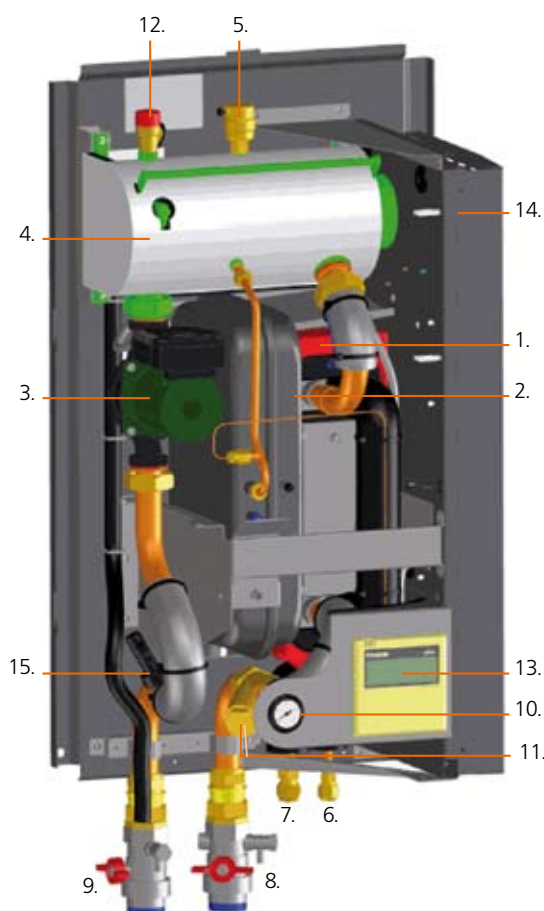

## EXTRA POSSIBILITIES THANKS TO THE INDOOR UNIT...

### Heating and Cooling

If you choose for Altherma with an indoor unit EKHBX, it can not only heat the house, but also cool it. The heat pump is then equipped with a reversible 4-way valve whereby the cooling cycle is reversed and heat is removed from the rooms. The indoor unit can cool rooms via under floor cooling or via fan coil units.

### Set temperature limits

To prevent incorrect manual adjustments, temperature limits can be implemented for both cooling and heating. With under floor heating, for example, it is important that the temperature of the water is adapted to the type of floor element. To prevent condensation problems, the temperature for floor cooling can never be lower than 18°C. For fan coil units, the water temperature can be allowed to decrease to 5°C.

### 1.3 - THE USER INTERFACE

With the easy to reach digital user interface in the indoor unit, controlling the Altherma system is also child's play for your customer. The display also offers a great deal of useful information:



- > Day of the week
- > Time
- > Operating mode  
(heating or cooling, heating domestic hot water, low-noise operating outdoor unit)
- > Room thermostat
- > Inspection
- > Compressor operation
- > Pump operation
- > Back-up operation
- > Booster heating operation  
(in the hot water tank)
- > Error codes for alarm
- > Temperature  
(outdoor temperature, temperature in hot water tank, leaving water temperature at indoor unit exit)



#### DID YOU KNOW...

- your customer can select a maximum of five time periods each day during which the following functions will or will not be activated:
  - > low-noise operation of the outdoor unit
  - > electric booster heater in the hot water tank
  - > heating of the domestic water
  - > reduction of the water temperature
- the five time periods per function are repeated daily. Your customer can still manually adjust the system when he stays home unexpectedly or stays up later. These settings are automatically switched off at the next programmed event.

## 2 - THE DOMESTIC HOT WATER TANK

- > available in 3 capacities: 150, 200 and 300 litres.
- > a thermistor in the hot water tank controls a 3-way valve and/or booster heater via the indoor unit.
- > hygienic design in stainless steel or enamelled steel.
- > 40 mm cfc-free insulation material (polyurethane) for stainless steel tanks and 50 mm enamelled steel tanks.
- > contains 2 heating elements: a heat exchanger at the bottom where the hot water from the indoor unit circulates and an extra 3 kW electric heater at the top.
- > 150 litre tank available in floor or wall mounted model, 200 and 300 litre only available as floor model.

1. Domestic hot water outlet
2. Pressure safety valve connection
3. Switch box
4. Switch box cover
5. Booster heater
6. Thermistor opening
7. Indoor unit water inlet
8. Heat exchanger
9. Indoor unit hot water outlet
10. Cold water inlet

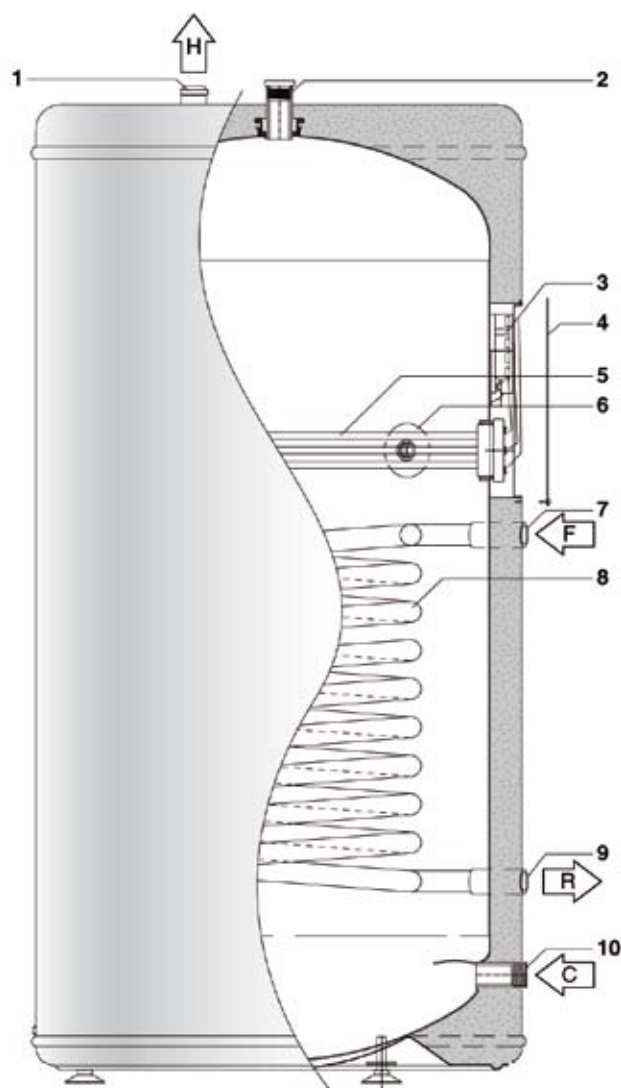

# ALThERMA. TECHNICALLY

## MULTIFUNCTIONAL HOT WATER TANK ...

### > Enamelled or stainless steel

To meet the needs of everyone, Daikin offers 2 types of supply tanks: either a tank made of stainless steel or a tank which has been enamelled. These are equipped with a sacrificial anode to protect the tank against corrosion.

### > Anti-legionella function

To prevent the development of legionella bacteria, the hot water tank is equipped with an anti-legionella function. You can set up the programme so that the water is heated to a specific temperature (standard setting = 70°C) at a set time on one or more days of the week.

### > Flexible control

It is possible to set "priority setting" for the production of domestic hot water. In this way the customer has domestic hot water available at any time of the day.

The heating of the domestic hot water can also be set up according to the night tariff. Another opportunity for rational energy consumption.

### > Regulating switch-on and shut-off temperatures

You personally set the minimum and maximum temperature when the water in the tank must be heated by the heat pump for the customer.

### > Delaying booster heater switch-off

To prevent the booster heater from switching on and off too often, you can allow the system to switch off as soon as the temperature reaches a maximum of 4°C higher than the set temperature.

### > Allowing back-up heater and booster heater to work separately

Programming the system to prevent the simultaneous operation of the back-up heater and the booster heater is also possible. An interesting possibility for homes with a limited current load!



## DID YOU KNOW...

your customers with a solar boiler can enjoy wonderful hot water at any time, even when the sun is not shining? An integrated re-heater is included in the system to help the sun on cloudy days.

## THE FUTURE: SOLAR BOILER

Averaged over an entire year, the sun delivers half of the energy we need to bring our domestic water up to the desired temperature for free. Your customer can use this free solar energy by connecting a solar boiler to his Altherma system. A solar boiler is a thermal solar-energy system whereby solar rays are transformed into heat. The heat is then stored in a water supply tank.

### Altherma solar boiler assembly

- > solar collector (to be supplied by the installer)
- > plumbing network and solar pump station (to be supplied by the installer)
- > supply tank:
  - standard Altherma domestic hot water tank
- > solar kit
- > re-heater
  - (Altherma heat pump with indoor unit which also provides the home with heating)

## SOLAR KIT

The solar kit provides the transfer of solar heat to the Altherma hot water tank via an external heat exchanger. In contrast to tanks with two heat exchangers, this system allows the entire content of the tank to be efficiently heated with solar heat and, if necessary, with heat pump energy.

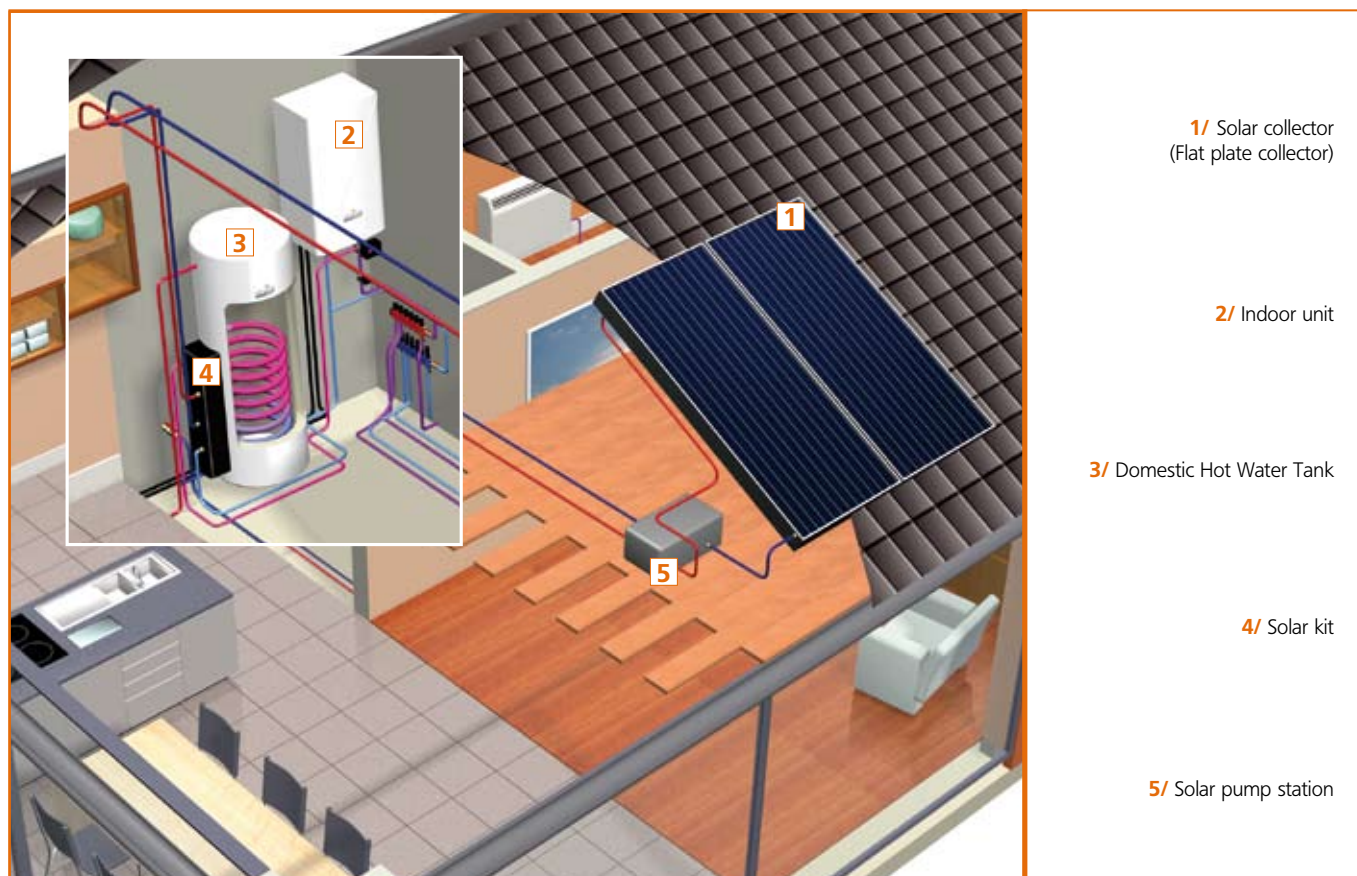

# ALTHERMA. TECHNICALLY



## DID YOU KNOW...

with an Altherma heat pump, the temperature of the domestic water can go up to 85°C, the temperature of the hot water for heating ranges between 15 and 55°C (50°C for smaller models) and the temperature of the cold water for cooling between 5 and 22°C?

## UNIQUE BENEFITS

### **Control customised to your customer**

The water temperature changes in function with the outside temperature so that your customer can enjoy a stable level of heating at any time. As the installer, you set up the system according to the desires of your customer. You input four temperatures to determine the "heating curve" and in doing so, you perfectly tune the Altherma system to the type of home.

### **Automatic re-start after power interruption**

In the event of a power interruption of up to two hours, the system automatically resumes with the set parameters.

### **Whisper-quiet operation**

The outdoor unit makes hardly any noise thereby leaving your customer's (and his neighbour's) peace and quiet undisturbed. You can even set the outdoor unit to produce 10dB(A) less noise during the night.

### **Electric back-up heating**

Every Altherma system is equipped with a back-up heater (heating capacity of 3, 6 or 9 kW). This unit can be used for supplemental heating during extremely cold outdoor temperatures or as a back-up in case of any problems with the outdoor unit. Your customer can then enjoy comfortable heating at any moment.

The operation of the back-up heater can be coupled to the outside temperature. The back-up heater will then only operate when outside temperatures are low.

### 3 - THE ROOM THERMOSTAT

The large LCD screen of the room thermostat indicates all the necessary information regarding the setting of the Altherma system in the blink of an eye. The user can also easily navigate between the different menus whose most common functions and modes include:

- > Setting the temperature of the room based on measurements from the built-in or external sensor
- > Cooling and heating mode
- > Off function (with integrated frost-protection function)
- > Holiday function mode
- > Comfort and reduced function modes
- > Time (day and month)
- > Programmable week timer with 2 standard and 5 pre-set programmes
- > Keylock function
- > Setting limits. The installer can change the upper and lower limits

Functions	Wired room thermostat EKRTW	Wireless room thermostat EKTR
Heating only	X	X
Heating and cooling	X	X
Comfort function mode	X	X
Reduced function mode	X	X
Scheduled function mode	X	X
Number of setpoint changes	12/day	12/day
Holiday function mode	X	X
Off function	X	X
Setpoint limitation	X	X
Keylock function	X	X
Floor temperature protection*	-	X

\*only in combination with EKRTETS

# 3. ALTHERMA. ECONOMICALLY

Customers today are, more than ever, conscious of the cost of heating.

There is not only the increasing cost of fuel oil and natural gas, but also the limited supply of fossil fuels and the problem of CO<sub>2</sub> emissions.

Energy efficient heating solutions are gaining in popularity.

The graphic below illustrates the positive influence of the Altherma heat pump on energy consumption and in comparison with heating systems which operate on gas or fuel oil.

## 1/ 66 To 80% Free

A heat pump boiler works more efficiently and saves more energy than a traditional heating system using fossil fuel. Altherma generates at least 3 to 5 kW of free heat per 1kW of electricity used. Talk about a good investment.

### OPERATING COSTS:

Conditions: Required annual heating energy: 20,000 kWh. Source: Energy prices based on EUROSTAT statistics [first semester 2007].

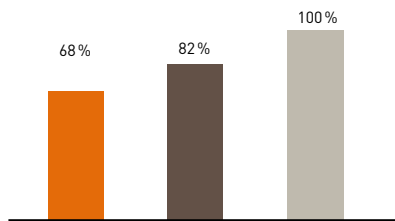

## 2/ PER (primary energy ratio)

This is the relationship between the useable energy generated and the primary energy consumed, with consideration for the electricity production efficiency and the electricity distribution.

### LOW PRIMARY ENERGY CONSUMPTION

Conditions : For combustion systems, the PER indicates the overall efficiency of the system, while for heat pumps it is equal to the seasonal performance factor multiplied by the electricity production efficiency which on average is 0.4 in the EU.

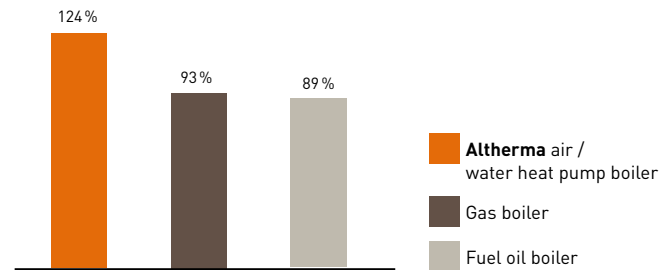

## DID YOU KNOW...

A small amount of ventilation in highly insulated houses provides for a healthy interior environment. The principle is simple: fresh air enters and contaminated air is removed.

In total, there are 4 ways in which air can be introduced and removed. But there is only one that is energy efficient, and that is ventilation with heat recuperation. A maximum amount of energy is recuperated from the contaminated air and transferred to the fresh air.

By equipping the home with a ventilation system that includes heat recuperation, the heating requirement decreases and the quality of the home increases.

## AVERAGE ANNUAL CO<sub>2</sub> EMISSIONS

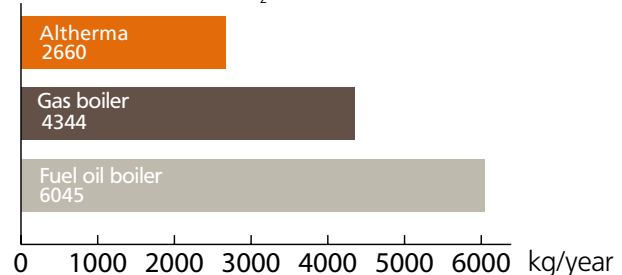

Calculation based on data from Eurelectric (organisation of European electricity producers), "Eurelec Program - 2001" for EU27

## LOWER CO<sub>2</sub> EMISSIONS

Altherma produces no direct CO<sub>2</sub> emissions, so you personally contribute to a better environment. The pump does use electricity, but even without renewable electricity the CO<sub>2</sub> emissions are still much lower than boilers that use fossil fuels.



# 4. ALTHERMA. THE SOFTWARE

Daikin's Altherma software programme allows quick and easy indication of the benefits of an Altherma system.

By specifying a number of parameters such as the location, the surface area to be heated, the required heating capacity, the entry and exit water temperatures of the distribution network and the local energy prices, the programme displays the following simulation details:

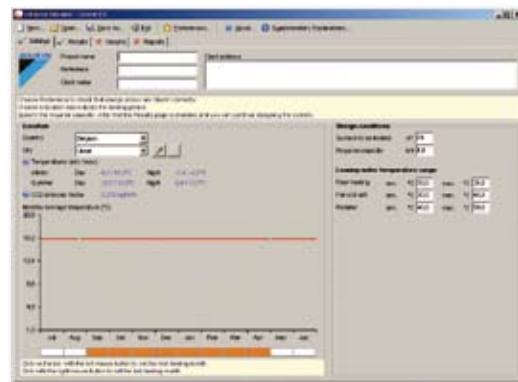

1. Material list with technical specification
2. Simulation graphics:
  - a) Required and available heating capacity with indication of the SPF (or Seasonal COP)
  - b) Duration of the heating period as a function of the outside temperature
  - c) The annual energy cost compared with a heating system using gas or fuel oil
  - d) The annual amount CO<sub>2</sub> emitted in tonnes compared with a heating system using gas or fuel oil
  - e) The monthly energy consumption in kWh
  - f) The monthly energy cost in €
  - g) The total amount of thermal energy in kWh as a function of the outside temperature
  - h) The radiated heat per m<sup>2</sup> (in kWh/m<sup>2</sup>) per month

All data is collected in a separate report. If you are interested in this software, contact your local distributor

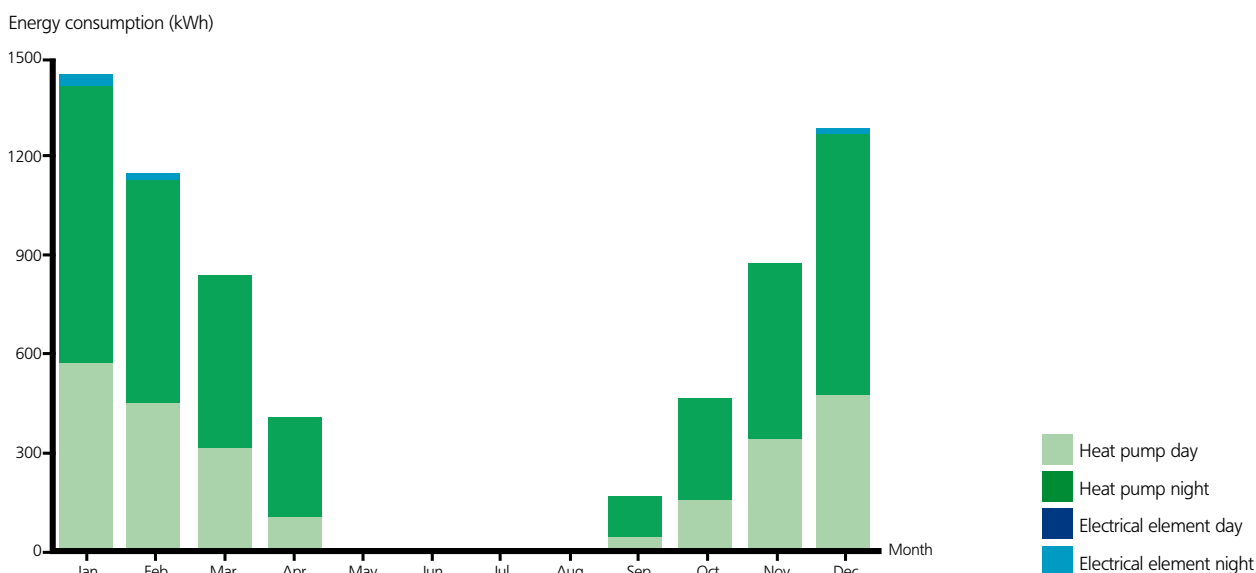

# 5. ALTHERMA. TECHNICAL SPECIFICATIONS

## 1. Application "heating only" with a room thermostat connected to the indoor unit

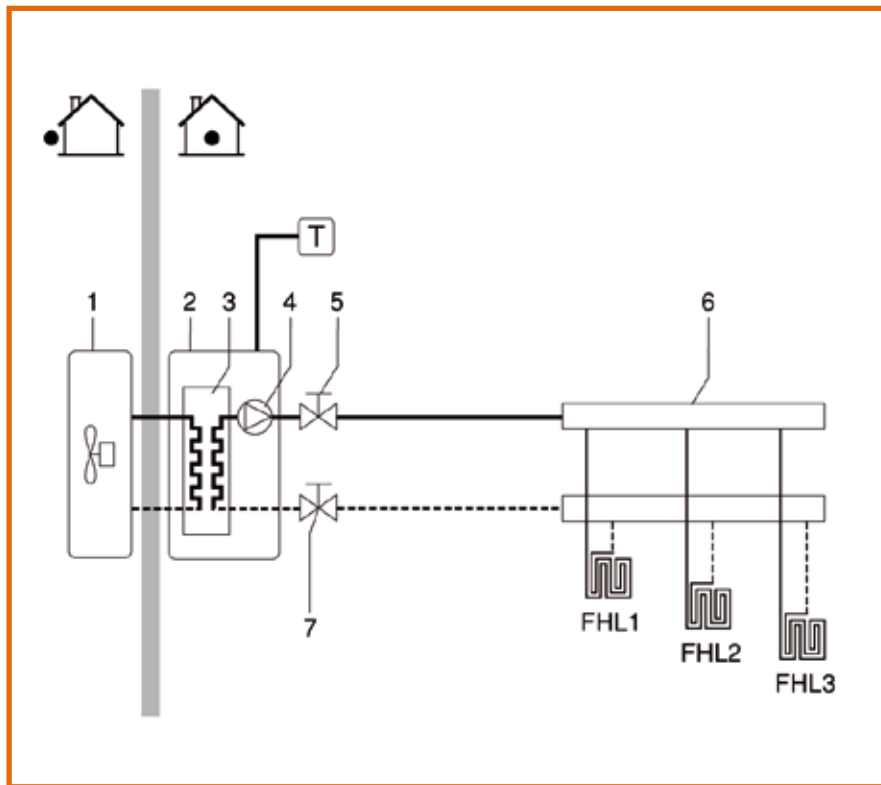

- 1. Outdoor unit
- 2. Indoor unit
- 3. Heat exchanger
- 4. Pump
- 5. Valve
- 6. Manifold (SBI)
- 7. Valve

FHL1...3 (Under) floor heating loop (SBI)  
 T Room thermostat

## 2. Application "heating" and "production of domestic hot water"

The temperature in each room is regulated by a valve on every water circuit. Hot water for domestic use is delivered by the domestic hot water tank connected to the indoor unit.

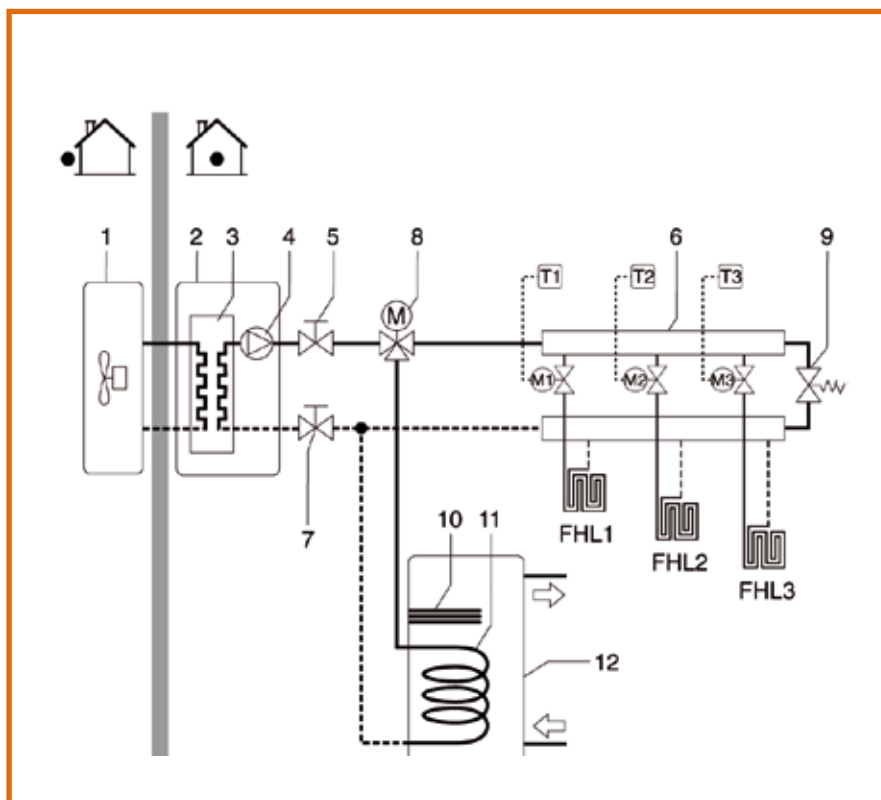

- 1. Outdoor unit
- 2. Indoor unit
- 3. Heat exchanger
- 4. Pump
- 5. Valve
- 6. Manifold (SBI)
- 7. Valve
- 8. Motorised 3-way valve
- 9. Pressure relief valve
- 10. Booster heater
- 11. Heat exchanger spiral
- 12. Tank for domestic hot water

FHL1...3 (Under) floor heating loop (SBI)  
 T 1...3 Individual room thermostat

SBI: Supplied by installer

### 3. Application "heating/cooling" via room thermostat and "production of domestic hot water"

Heating using under floor heating loops and fan coil units. Cooling using only the fan coil units. Hot water for domestic use is delivered by the domestic hot water tank connected to the indoor unit.

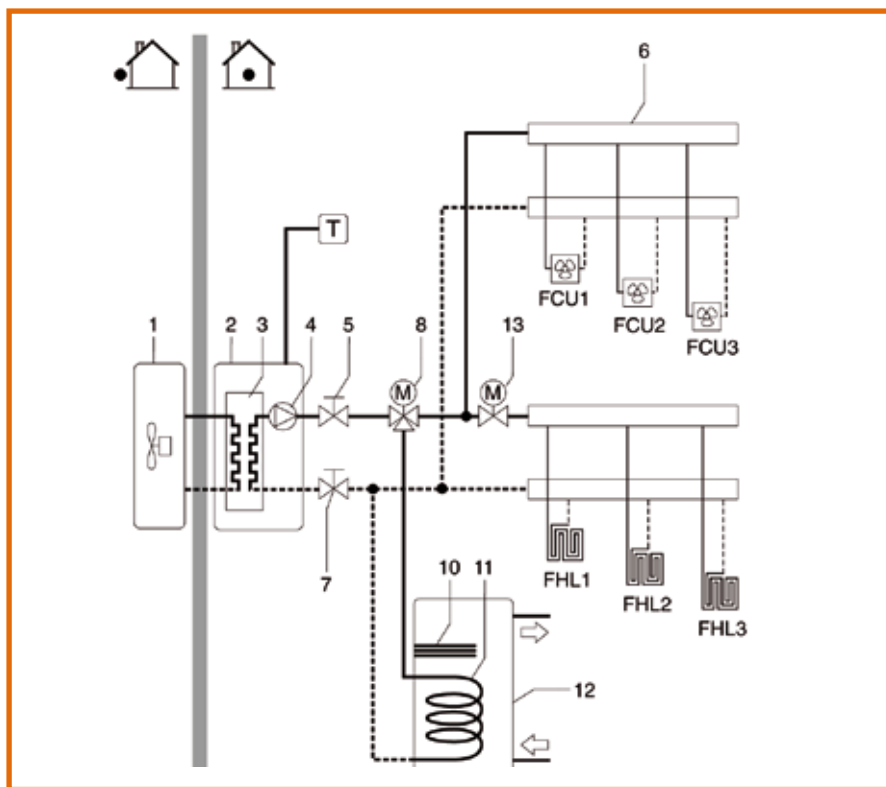

- 1. Outdoor unit
- 2. Indoor unit
- 3. Heat exchanger
- 4. Pump
- 5. Valve
- 6. Manifold (SBI)
- 7. Valve
- 8. Motorised 3-way valve
- 10. Booster heater
- 11. Heat exchanger spiral
- 12. Tank for domestic hot water
- 13. Motorised 2-way valve (SBI)

FCU1...3 Fan coil unit (SBI)  
 FHL1...3 (Under) floor heating loop (SBI)  
 T Room thermostat with cooling / heating switch

### 4. Bivalent application

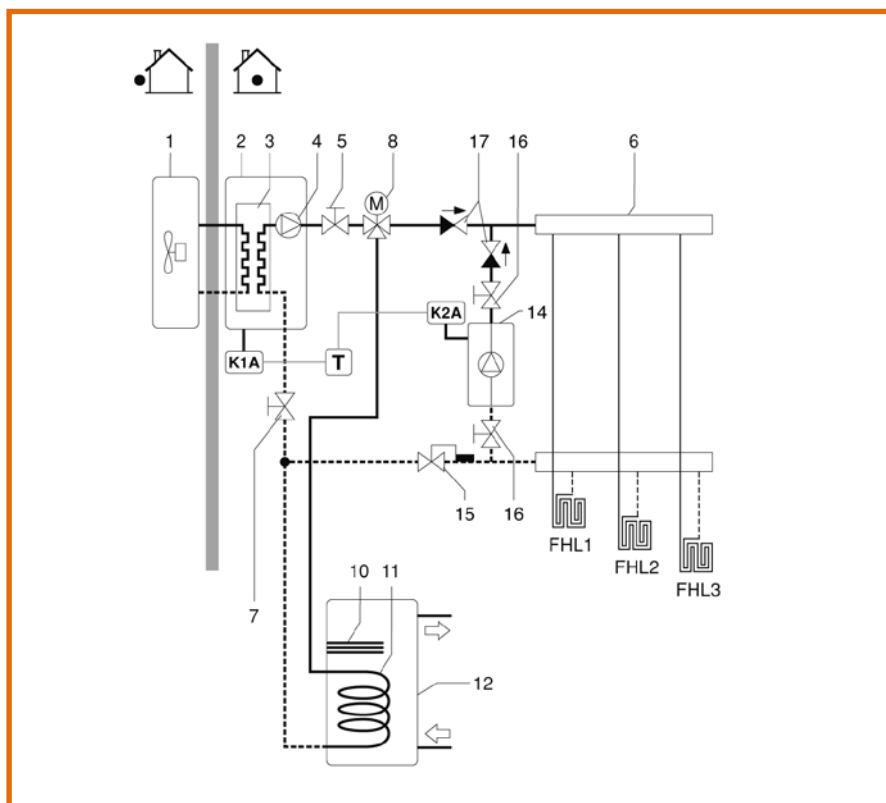

- 1. Outdoor unit
- 2. Indoor unit
- 3. Heat exchanger
- 4. Pump
- 5. Valve
- 6. Manifold (SBI)
- 7. Valve
- 8. Motorised 3-way valve
- 10. Booster heater
- 11. Heat exchanger spiral
- 12. Tank for domestic hot water
- 14. External heating device (SBI)
- 15. Aquastat (SBI)
- 16. Valve (SBI)
- 17. One-way valve (SBI)

FHL1...3 (Under) floor heating loop (SBI)  
 K1A Relay for activating EKHB\*unit (SBI)  
 K2A Relay for activating hot water tank (SBI)  
 T Room thermostat

SBI: Supplied by installer

## INDOOR UNIT



			EKHBH008AA***	EKHBX008AA***	EKHBH016AB***	EKHBX016AB***
Function			Heating only		Reversible	
Dimensions	HxWxD	mm	922x502x361		922x502x361	
Leaving water temperature range	heating	°C	15~50			
	cooling	°C	-		5~22	
Drain valve			yes			
Material			Epoxy polyester painted galvanised steel			
Colour			Neutral white (RAL 9010)			
FACTORY MOUNTED HEATER			kW	capacity steps	power supply	
EKHBH(X)008AA3V3 / EKHBH(X)016AB3V3			3	1	1~/230V	
EKHBH(X)008AA6V3 / EKHBH(X)016AB6V3			6	2	1~/230V	
EKHBH(X)008AA6WN / EKHBH(X)016AB6WN			6	2	3~/400V	
EKHBH(X)008AA6T1 / EKHBH(X)016AB6T1			6	2	3~/230V	
EKHBH(X)008AA9WN / EKHBH(X)016AB9WN			9	2	3~/400V	
EKHBH(X)008AA9T1 / EKHBH(X)016AB9T1			9	2	3~/230V	

## OUTDOOR UNIT



			ERHQ006AD	ERHQ007AD	ERHQ008AD
Dimensions	HxWxD	mm	735x825x300		
Nominal capacity	heating	kW	5.75	6.84	8.43
	cooling	kW	7.20	8.16	8.37
Nominal input	heating	kW	1.26	1.58	2.08
	cooling	kW	2.27	2.78	2.97
COP			4.56	4.34	4.05
EER			3.17	2.94	2.82
Operation range	heating	°C	-20~25		
	cooling	°C	10~43		
	domestic water	°C	-20~43		
Sound power level	heating	dBa	61	61	62
	cooling	dBa	63	63	63
Sound pressure level	heating	dBa	48	48	49
	cooling	dBa	48	48	50
Weight			56		
Refrigerant charge	R-410A	kg	1.7		
Power supply			1~/230V/50Hz		
Recommended fuses			A 20		

Measuring conditions: Heating Ta DB/WB 7°C/6°C - LWC 35°C (DT=5°C) - Cooling Ta 35°C - LWE18°C (DT=5°C)



			ERHQ011A	ERHQ014A	ERHQ016A	ERHQ011AW1	ERHQ014AW1	ERHQ016AW1
Dimensions	HxWxD	mm	1,170x900x320			1,345x900x320		
Nominal capacity	heating	kW	11.2	14.0	16.0	11.32	14.50	16.05
	cooling	kW	13.9	17.3	17.8	15.05	16.06	16.76
Nominal input	heating	kW	2.46	3.17	3.83	2.54	3.33	3.73
	cooling	kW	3.79	5.78	6.77	4.44	5.33	6.06
COP			4.55	4.42	4.18	4.46	4.35	4.30
EER			3.67	2.99	2.63	3.39	3.01	2.76
Operation range	heating	°C	-20~35			-20~35		
	cooling	°C	10~46			10~46		
	domestic water	°C	-20~43			-20~43		
Sound power level	heating	dBa	64	64	66	64	64	66
	cooling	dBa	64	66	69	64	66	69
Sound pressure level	heating	dBa	49	51	53	51	51	52
	cooling	dBa	50	52	54	50	52	54
Weight			103			108 / 110*		
Refrigerant charge	R-410A	kg	3.7			2.95		
Power supply			1~/230V/50Hz			3N~/400V/50Hz		
Recommended fuses			A 32			20		

Measuring conditions: Heating Ta DB/WB 7°C/6°C - LWC 35°C (DT=5°C) - Cooling Ta 35°C - LWE18°C (DT=5°C)

\*Specific models with additional protection against freezing are available and are designated with the suffix "8" (example ERHQ011AW18)

## DOMESTIC HOT WATER TANK



		EKHWS150B3V3	EKHWS200B3V3	EKHWS300B3V3	EKHWS200B3Z2	EKHWS300B3Z2
Water volume	l	150	200	300	200	300
Max.water temperature	°C	85				
Height	mm	900	1,150	1,600	1,150	1,600
Diameter	mm	580				
Booster heater	kW	3				
Power supply		1~/230V/50Hz			2~/400V/50Hz	
Material inside tank		Stainless steel (DIN 1.4521)				
Material outside casing		Epoxy-coated mild steel				
Colour		Neutral white				
Empty weight	kg	37	45	59	45	59

		EKHWE150A3V3	EKHWE200A3V3	EKHWE300A3V3	EKHWE200A3Z2	EKHWE300A3Z2	EKHWE150A3V3
Mounting		Floor					Wall
Water volume	l	150	200	300	200	300	150
Max.water temperature	°C	75					
Height	mm	1,205	1,580	1,572	1,580	1,572	1,205
Diameter	mm	545	545	660	545	660	545
Booster heater	kW	3					
Power supply		1~/230V/50Hz			2~/400V/50Hz		1~/230V/50Hz
Material inside tank		Enamel coated steel acc. (DIN4753TL2)					
Material outside casing		Epoxy coated steel					
Colour		Natural white (RAL 9010)					
Empty weight	kg	80	104	140	104	140	82

## SOLAR KIT



			EKSOLHWAV1
Dimensions	HxWxD	mm	770x305x270
Heat exchanger	pressure drop	kPA	21.5
	max.inlet temp	°C	110
	heat exchange capacity	W/K	1,400
Ambient temperature	max.	°C	35
	min.	°C	1
Power supply			1~/220-240V/50Hz
Power supply intake			indoor unit

## ROOM THERMOSTAT

 thermostat - receiver  
(wireless)

			EKRTW	EKRTR		EKRTETS (option)
				Thermostat	Receiver	
Dimensions	HxWxD	mm	87x125x34	87x125x34	170x50x28	3m wire length
Weight	Net weight	g	215	210	125	65
Ambient temperature	Storage	°C	-20~60	-20~60	-20~60	-20~60
	Operation	°C	0~50	0~50	0~50	0~50
Temperature setpoint range	Heating	°C	4~37	4~37	-	-
	Cooling	°C	4~37	4~37	-	-
Clock			yes	yes	-	-
Regulation function			proportional band	proportional band	-	-

## 6. DAIKIN, ALWAYS AT YOUR SERVICE

### SERVICE FROM A TO Z

Altherma can be used in different configurations: on its own, with an electric back-up heater or in combination with an existing fossil fuel boiler. To install your Altherma total solution, you can rely on a certified installer in your area. They will have all of the necessary expertise and experience to place your comfort system quickly and correctly, so it would always perform optimally.



**You can always rely on Daikin:  
we are there to help you!**

# ALTHERMA. THE TOOLS

The following product brochures are available for you:

## A folder for private customers

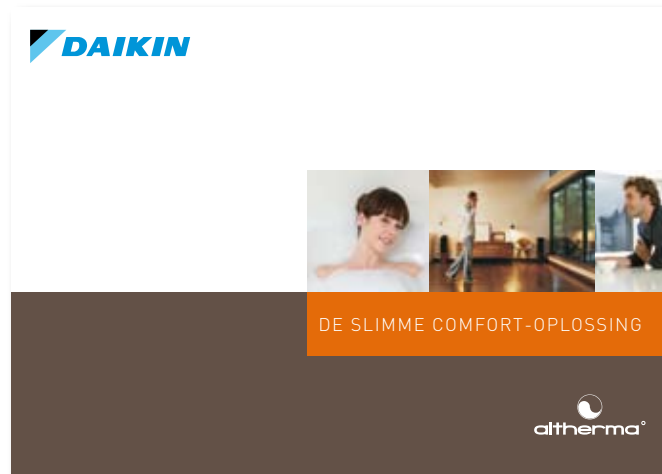

## Technical folders



To help convince your customers, Daikin also provides **a software package**.

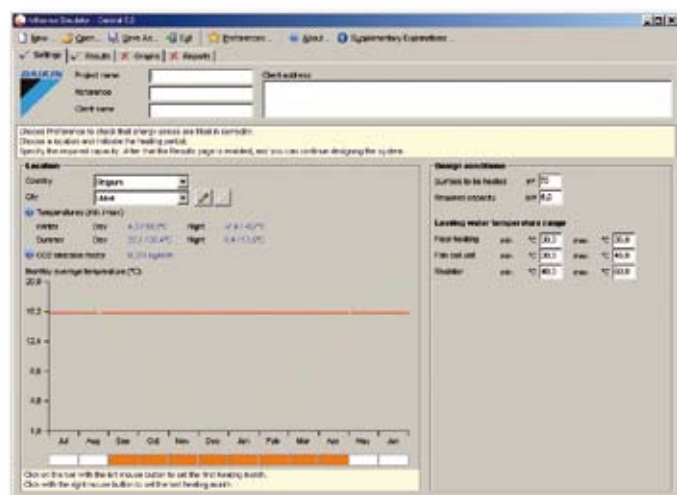

You can also direct the customer to the Altherma website: [www.altherma.eu](http://www.altherma.eu)



Daikin's unique position as a manufacturer of air conditioning equipment, compressors and refrigerants has led to its close involvement in environmental issues. For several years Daikin has had the intention to become a leader in the provision of products that have limited impact on the environment.

This challenge demands the eco design and development of a wide range of products and an energy management system, resulting in energy conservation and a reduction of waste.



Daikin Europe N.V. is approved by LRQA for its Quality Management System in accordance with the ISO9001 standard. ISO9001 pertains to quality assurance regarding design, development, manufacturing as well as to services related to the product.



ISO14001 assures an effective environmental management system in order to help protect human health and the environment from the potential impact of our activities, products and services and to assist in maintaining and improving the quality of the environment.



Daikin units comply with the European regulations that guarantee the safety of the product.



Daikin Europe N.V. participates in the Eurovent Certification Programme for Air Conditioners (AC), Liquid Chilling Packages (LCP) and Fan Coil Units (FC); the certified data of certified models are listed in the Eurovent Directory.

The present leaflet is drawn up by way of information only and does not constitute an offer binding upon Daikin Europe N.V.. Daikin Europe N.V. has compiled the content of this leaflet to the best of its knowledge. No express or implied warranty is given for the completeness, accuracy, reliability or fitness for particular purpose of its content and the products and services presented therein. Specifications are subject to change without prior notice. Daikin Europe N.V. explicitly rejects any liability for any direct or indirect damage, in the broadest sense, arising from or related to the use and/or interpretation of this leaflet. All content is copyrighted by Daikin Europe N.V.

Daikin products are distributed by:



**DAIKIN EUROPE N.V.**

Naamloze Vennootschap  
Zandvoordestraat 300  
B-8400 Oostende, Belgium  
www.daikin.eu  
BTW: BE 0412 120 336  
RPR Oostende